

THIS DRAWING IS UNPUBLISHED. RELEASED FOR PUBLICATION 20  
 © COPYRIGHT 20 BY - ALL RIGHTS RESERVED.

REVISIONS					
P	LTR	DESCRIPTION	DATE	DWN	APVD
	AC	REDRAWN/REVISED PER ECO-17-001755	22NOV2017	GR	JO

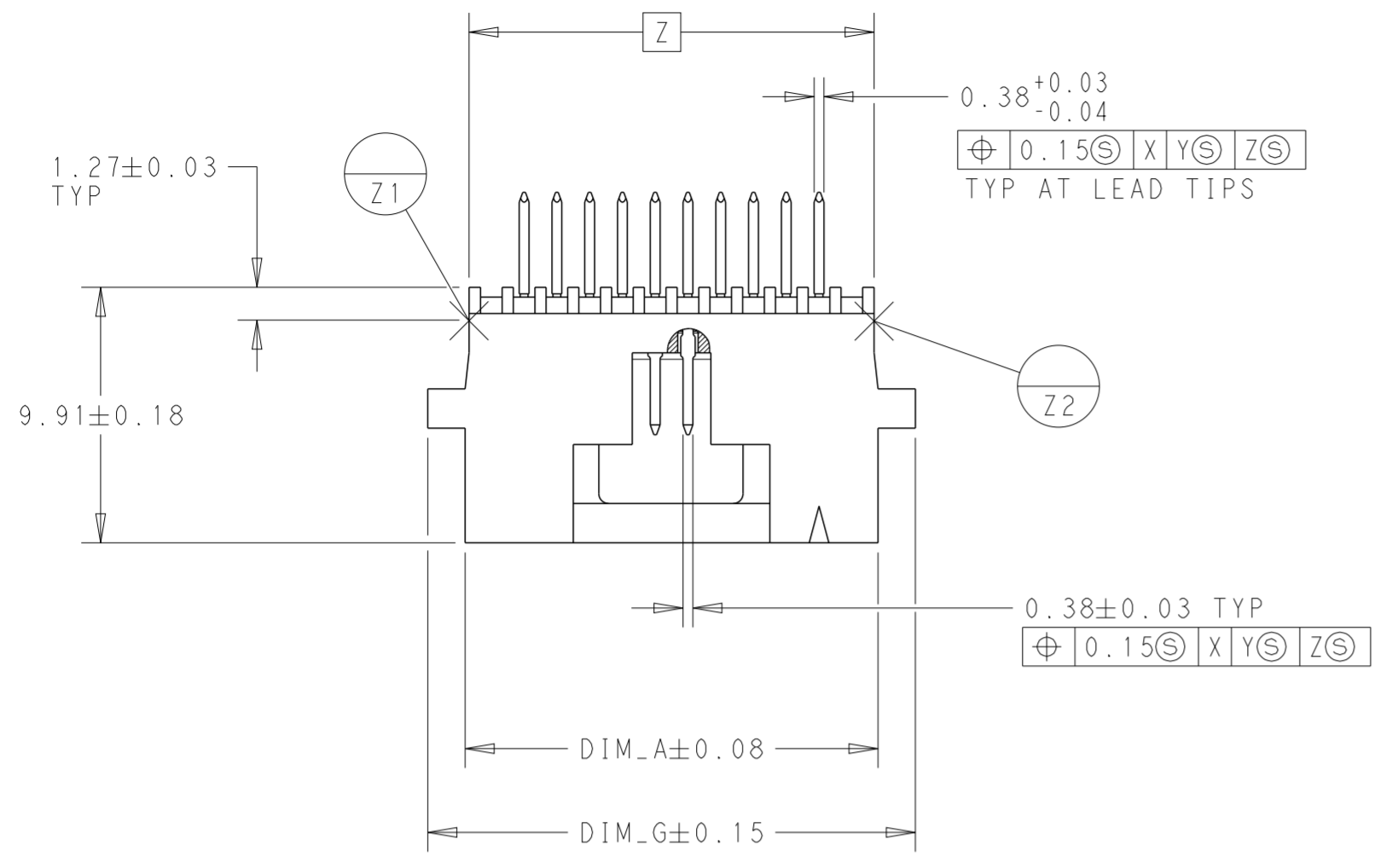

- 1 CONTACT AREA PLATED WITH  $0.76 \mu\text{m}$  MIN GOLD; SOLDER LEADS PLATED WITH  $3.81 \mu\text{m}$  MIN TIN-LEAD, ALL OVER  $1.27 \mu\text{m}$  MIN NICKEL
- 2 NOTE DELETED.
- 3 DIMENSION APPLIES AT BASE OF SHROUD.
- 4 THE NOTED DIMENSIONS APPLY AT THE INTERSECTION OF THE POST AND HOUSING
- 5 NOTE DELETED.
- 6 HOUSING: LCP, COLOR-BLACK. POSTS: COPPER ALLOY.
- 7 CONTACT AREA PLATED WITH  $0.76 \mu\text{m}$  MIN GOLD, SOLDER LEADS PLATED WITH  $3.81 \mu\text{m}$  MIN TIN, ALL OVER  $1.27 \mu\text{m}$  MIN NICKEL.
- 8 NOTE DELETED.
- 9 ROHS 2002/95/EC COMPLIANT.
- 10 FINISH:  $0.03 \mu\text{m}$  MIN. GOLD ON GOLD PLATED AREA,  $3.81 \mu\text{m}$  MATTE TIN LEAD ON TIN PLATE AREA, UNDER PLATING SHOULD BE  $1.27 \mu\text{m}$  NICKEL ON ENTIRE CONTACT, GOLD AND TIN PLATING MAY NOT OVERLAP
- 11 FINISH:  $0.03 \mu\text{m}$  MIN. GOLD ON GOLD PLATED AREA,  $3.81 \mu\text{m}$  MATTE TIN ON TIN PLATE AREA, UNDERPLATING TO BE  $1.27 \mu\text{m}$  NICKEL ON ENTIRE CONTACT, GOLD AND TIN PLATING MAY NOT OVERLAP
- 12 NOTE DELETED.

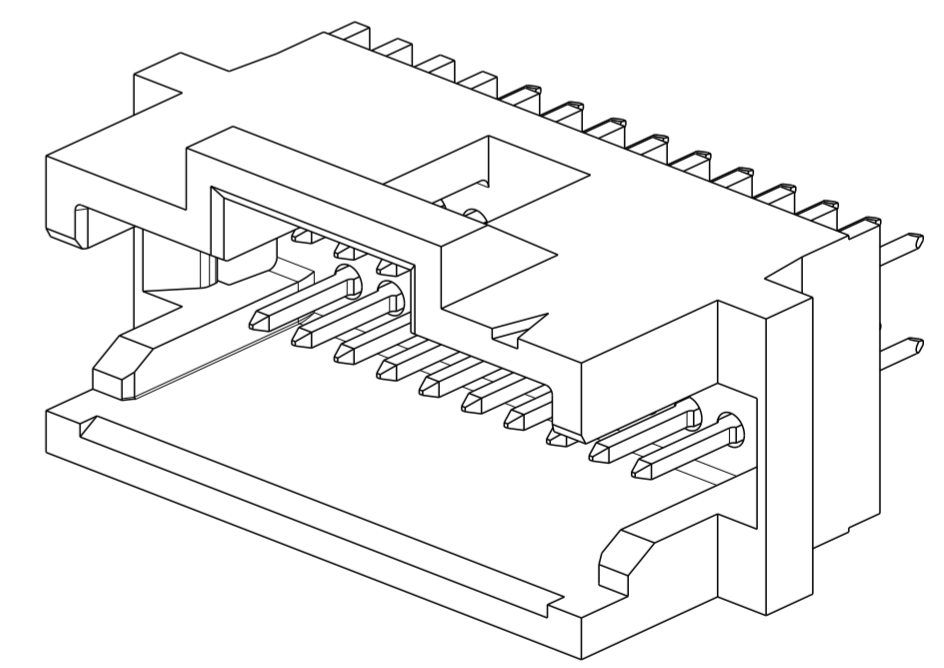
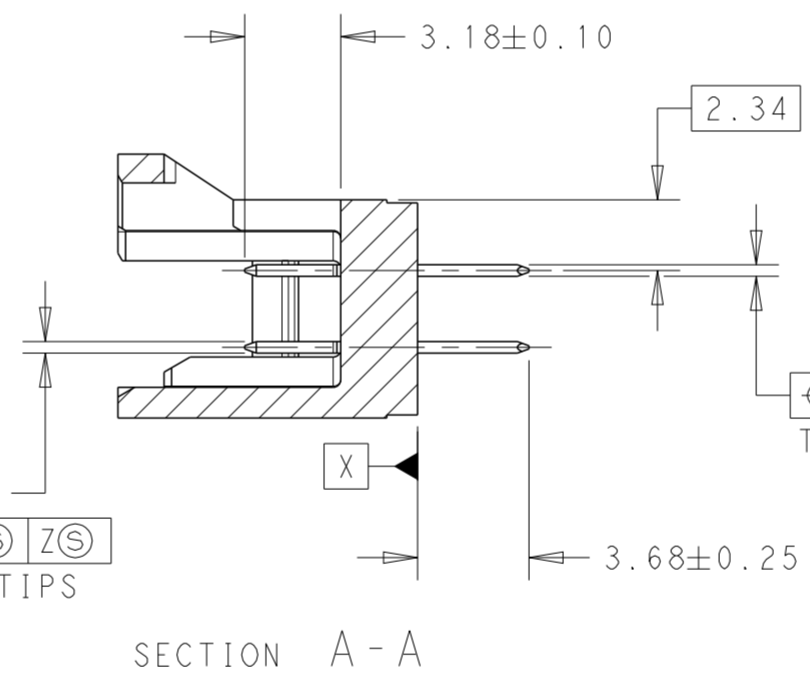
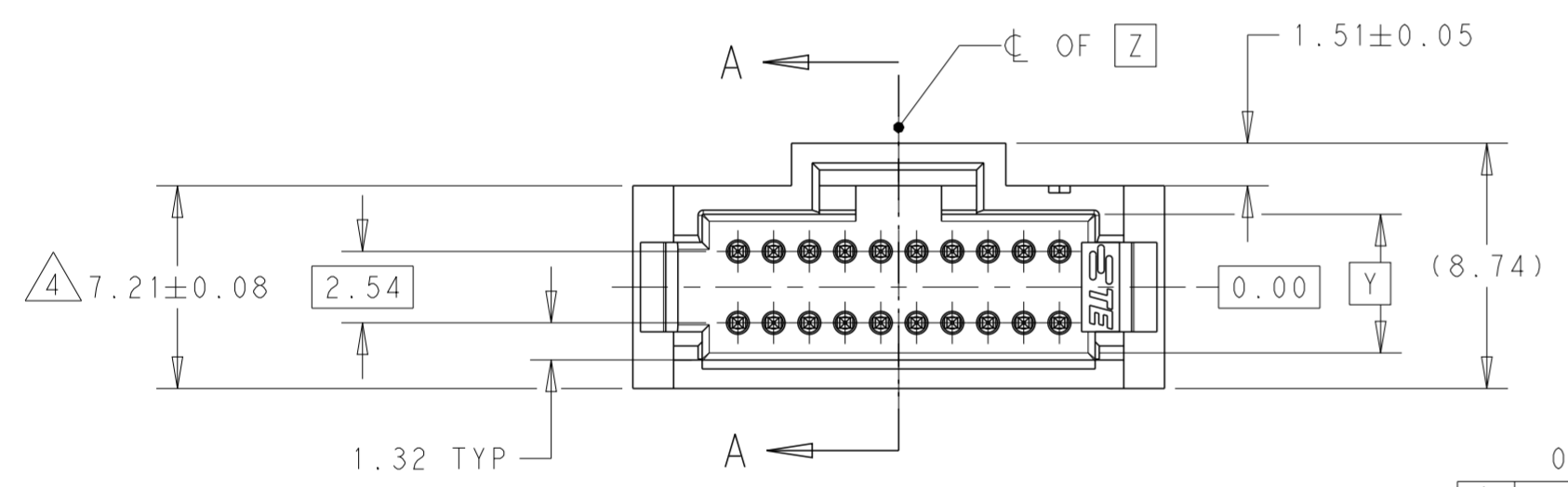

SCALE 6:1

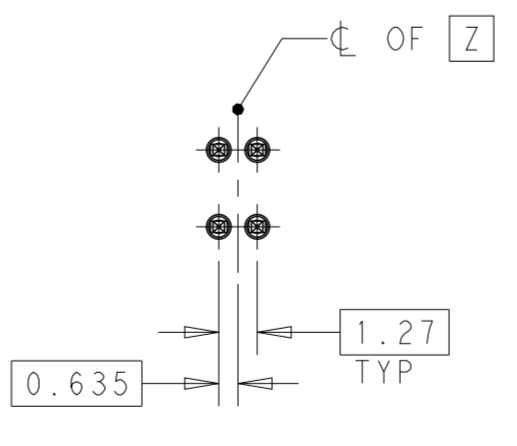
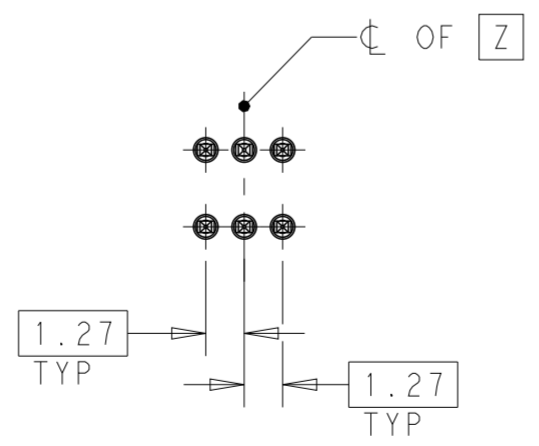
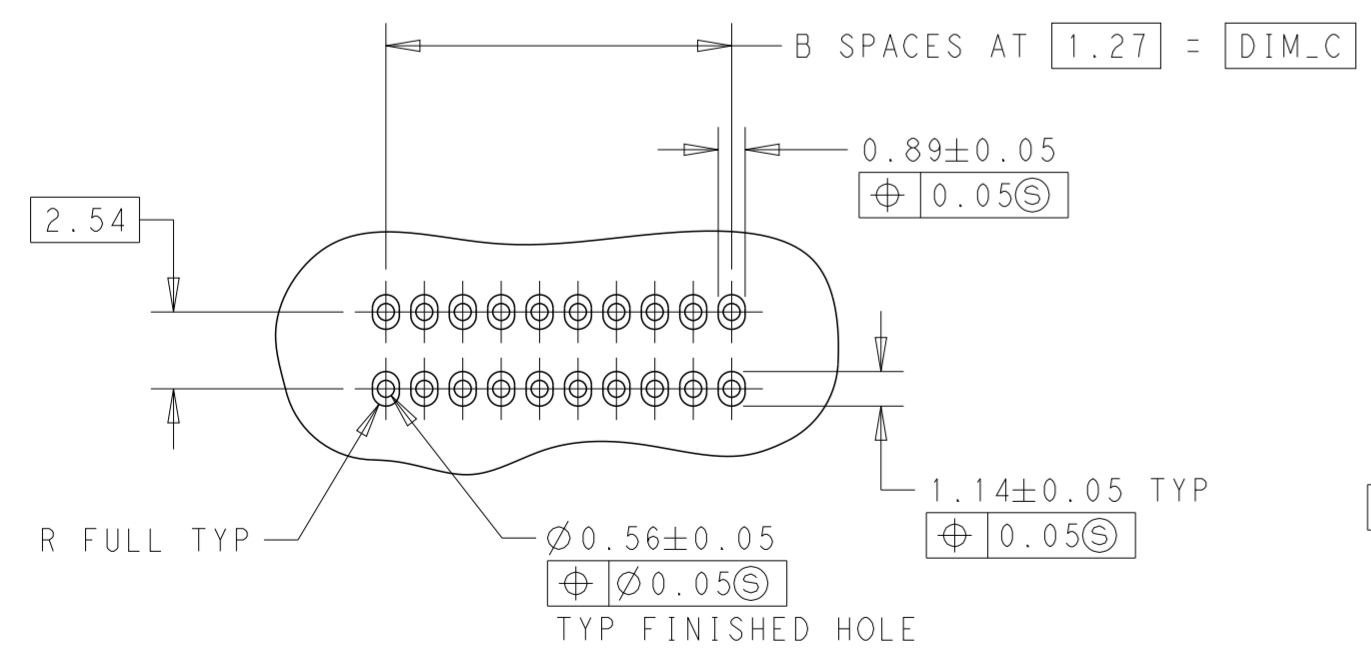

THIS DRAWING IS A CONTROLLED DOCUMENT.		DWN G. RAMESH 22NOV2017	TE Connectivity	
DIMENSIONS: mm		CHK J. OLSON 22NOV2017		
TOLERANCES UNLESS OTHERWISE SPECIFIED:		APVD J. OLSON 22NOV2017	NAME	
0 PLC ±		PRODUCT SPEC	HEADER ASSEMBLY, VERTICAL, DOUBLE ROW, W/SIDE & END LATCHES, AMPMODU System 50	
1 PLC ±0.3		APPLICATION SPEC	-	
2 PLC ±0.13		114-25031	SIZE	CAGE CODE
3 PLC ±		WEIGHT	A200779	C-104666
4 PLC ±		CUSTOMER DRAWING	SCALE 4:1	SHEET 1 OF 2
ANGLES ±0.5°				REV AC
FINISH				
SEE TABLE				

THIS DRAWING IS UNPUBLISHED. RELEASED FOR PUBLICATION 20  
 © COPYRIGHT 20 BY - ALL RIGHTS RESERVED.

REVISIONS					
P	LTR	DESCRIPTION	DATE	DWN	APVD
-		SEE SHEET 1	-	-	-

11	27.79	20.32	15	24.89	34	8-104666-3
	12.55	5.08	4	9.65	10	8-104666-2
	22.71	15.24	12	19.81	26	8-104666-1
	21.44	13.97	11	18.54	24	8-104666-0
	16.36	8.89	7	13.46	16	7-104666-9
	49.38	46.99	33	46.48	68	7-104666-8
	44.30	36.83	29	41.40	60	7-104666-7
	69.70	62.23	49	66.80	100	7-104666-6
	57.00	49.53	39	54.10	80	7-104666-5
	37.95	30.48	24	35.05	50	7-104666-4
	31.60	24.13	19	28.70	40	7-104666-3
	25.25	17.78	14	22.35	30	7-104666-2
	18.90	11.43	9	16.00	20	7-104666-1
7	27.79	20.32	15	24.89	34	6-104666-3
	12.55	5.08	4	9.65	10	6-104666-2
	22.71	15.24	12	19.81	26	6-104666-1
	21.44	13.97	11	18.54	24	6-104666-0
	16.36	8.89	7	13.46	16	5-104666-9
	49.38	46.99	33	46.48	68	5-104666-8
	44.30	36.83	29	41.40	60	5-104666-7
	69.70	62.23	49	66.80	100	5-104666-6
	57.00	49.53	39	54.10	80	5-104666-5
	37.95	30.48	24	35.05	50	5-104666-4
	31.60	24.13	19	28.70	40	5-104666-3
	25.25	17.78	14	22.35	30	5-104666-2
	18.90	11.43	9	16.00	20	5-104666-1
FINISH	DIM_G	DIM_C	B SPACES	DIM_A	NO OF POSN	PART NUMBER

10	27.79	20.32	15	24.89	34	3-104666-3
	12.55	5.08	4	9.65	10	3-104666-2
	22.71	15.24	12	19.81	26	3-104666-1
	21.44	13.97	11	18.54	24	3-104666-0
	16.36	8.89	7	13.46	16	2-104666-9
	49.38	46.99	33	46.48	68	2-104666-8
	44.30	36.83	29	41.40	60	2-104666-7
	69.70	62.23	49	66.80	100	2-104666-6
	57.00	49.53	39	54.10	80	2-104666-5
	37.95	30.48	24	35.05	50	2-104666-4
	31.60	24.13	19	28.70	40	2-104666-3
	25.25	17.78	14	22.35	30	2-104666-2
	18.90	11.43	9	16.00	20	2-104666-1
1	27.79	20.32	15	24.89	34	1-104666-3
	12.55	5.08	4	9.65	10	1-104666-2
	22.71	15.24	12	19.81	26	1-104666-1
	21.44	13.97	11	18.54	24	1-104666-0
	16.36	8.89	7	13.46	16	104666-9
	49.38	46.99	33	46.48	68	104666-8
	44.30	36.83	29	41.40	60	104666-7
	69.70	62.23	49	66.80	100	104666-6
	57.00	49.53	39	54.10	80	104666-5
	37.95	30.48	24	35.05	50	104666-4
	31.60	24.13	19	28.70	40	104666-3
	25.25	17.78	14	22.35	30	104666-2
	18.90	11.43	9	16.00	20	104666-1
FINISH	DIM_G	DIM_C	B SPACES	DIM_A	NO OF POSN	PART NUMBER

THIS DRAWING IS A CONTROLLED DOCUMENT.		DWN G. RAMESH 22NOV2017	 TE Connectivity	
DIMENSIONS: mm		CHK J. OLSON 22NOV2017		
TOLERANCES UNLESS OTHERWISE SPECIFIED:		APVD J. OLSON 22NOV2017	NAME HEADER ASSEMBLY, VERTICAL, DOUBLE ROW, W/SIDE & END LATCHES, AMPMODU System 50	
0 PLC ± 1 PLC ±0.3 2 PLC ±0.13 3 PLC ± 4 PLC ± ANGLES ±0.5° FINISH		PRODUCT SPEC 108-1093	SIZE 114-25031	
MATERIAL		APPLICATION SPEC 114-25031	CAGE CODE A200779	DRAWING NO C-104666
SEE TABLE		WEIGHT -	RESTRICTED TO	
		CUSTOMER DRAWING	SCALE 4:1	SHEET 2 OF 2
			REV AC	