

| TOLERANCE<br>UNLESS OTHERWISE<br>SPECIFIED |       |
|--|-------|
| .X   | ±0.25 |
| .XX  | ±0.13 |
| .XXX                                       | ±0.10 |

THIS IS A C.A.D. GENERATED DRAWING  
DO NOT MAKE MANUAL REVISIONS TO MASTER.

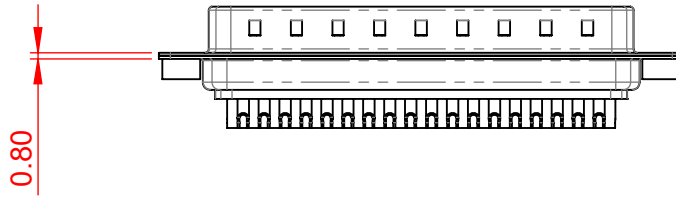

| ISSUE NUMBER |   |
|--------------|---|
| ORIGINAL     | ① |

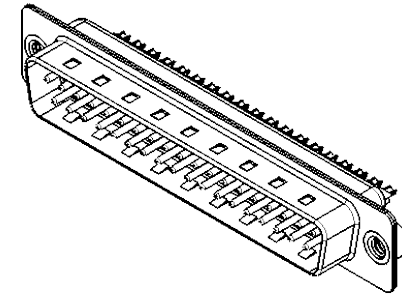
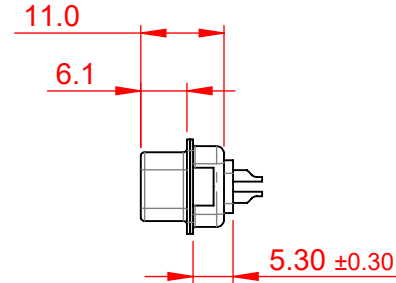
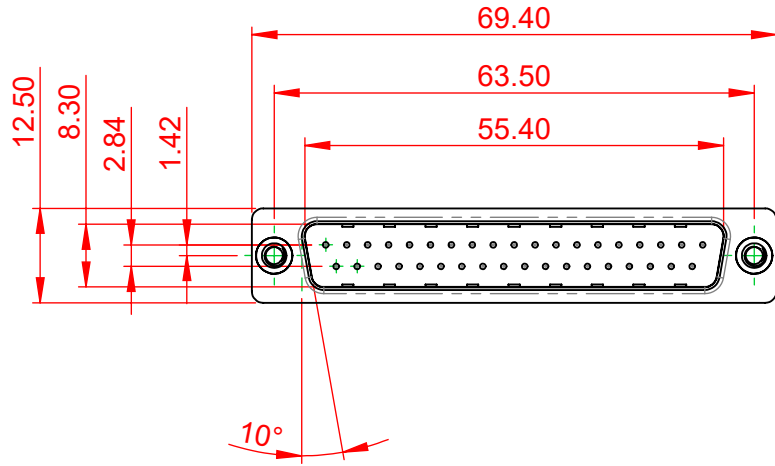



**NOTES:**

**MATERIAL:**  
**HOUSING:** PA6T THERMOPLASTIC, GREEN, UL94V-0  
**SHELL:** STEEL, NICKEL PLATED  
**CONTACT:** COPPER ALLOY, GOLD FLASH PLATED

**OPERATING TEMPERATURE:** -55°C ~ 125°C

**CURRENT RATING:** 5A PER CONTACT  
**CONTACT RESISTANCE:** 10mΩ MAX.  
**INSULATOR RESISTANCE:** 5000MΩ min.  
**DIELECTRIC WITHSTANDING VOLTAGE:** 1000V AC min.

| 627 SERIES D-SUB CONNECTOR  |       | SW REFERENCE NO.: 627 ASSEMBLY  |                    |
|---|-------|---------------------------------|--------------------|
|   |       | DRAWN: C.B                      | DATE: AUG. 01/2018 |
| CHECKED:  | DATE: | SCALE: 1:1                      | SHEET 1 OF 1       |
|  <b>EDAC INC</b><br>TORONTO, ONTARIO<br>CANADA<br>YOUR CONNECTION TO QUALITY & SERVICE                                     |       | DRAWING NUMBER: 627-M37-222-GN2 |                    |
|   |       | PART NUMBER: 627-M37-222-GN2    |                    |
|  <b>RoHS COMPLIANT</b><br>THIS SERIES FULLY CONFORMS TO<br>THE EUROPEAN UNION DIRECTIVES<br>2011/65/EU FOR RoHS COMPLIANCY. |       | <b>ISSUE</b><br>1               |                    |

 **RoHS COMPLIANT**  
 THIS SERIES FULLY CONFORMS TO  
 THE EUROPEAN UNION DIRECTIVES  
 2011/65/EU FOR RoHS COMPLIANCY.

 **EDAC INC**  
 TORONTO, ONTARIO  
 CANADA  
 YOUR CONNECTION TO QUALITY & SERVICE

THESE DRAWINGS AND SPECIFICATIONS  
 ARE THE PROPERTY OF EDAC INC., AND  
 SHALL NOT BE REPRODUCED, OR COPIED  
 OR USED AS THE BASIS FOR THE  
 MANUFACTURE OR SALE OF APPARATUS  
 WITHOUT WRITTEN PERMISSION.

|                                 |                    |
|---------------------------------|--------------------|
| SW REFERENCE NO.: 627 ASSEMBLY  |                    |
| DRAWN: C.B                      | DATE: AUG. 01/2018 |
| CHECKED:                        | DATE:              |
| SCALE: 1:1                      | SHEET 1 OF 1       |
| DRAWING NUMBER: 627-M37-222-GN2 |                    |
| PART NUMBER: 627-M37-222-GN2    |                    |
| <b>ISSUE</b>                    |                    |
| 1                               |                    |