



2.5GHz 1,6/5.6 N/O S.P.6 T. SWITCH

OPTIONS : /BCD DECODER /SUPP.DIODES

RF CHARACTERISTICS

NUMBER OF WAYS : 6
 FREQUENCY RANGE : 0 - 2.5 GHz
 IMPEDANCE : 75 Ohms

FREQUENCY (GHz)	0 - 1	1 - 2.5
V.S.W.R <=	1.20	1.30
INSERT. LOSS <=	0.20 dB	0.30 dB
ISOLATION >=	80 dB	70 dB
AVER. POWER (*)	400 W	240 W

ELECTRICAL CHARACTERISTICS

ACTUATOR : NORMALLY OPEN
 NOMINAL CURRENT AT 25° C (±10%) : 250 mA
 ACTUATOR VOLTAGE (Vcc) : 12V (10.2 to 13V) / NEGATIVE COMMON
 TERMINALS : solder pins (250°C max./30 sec.)
 BCD INPUTS (E) - High level : 3.5 to 5.5V / 800µA at 5V
 - Low level : 0 to 1.5V / 20µA at 0.8V

MECHANICAL CHARACTERISTICS

CONNECTORS : 1,6/5.6 female per IEC 169-13
 LIFE : 2.000.000 cycles per position
 SWITCHING TIME (nominal voltage;25° C) : < 15 ms
 CONSTRUCTION : splashproof
 WEIGHT : < 220 g

ENVIRONMENTAL CHARACTERISTICS

OPERATING TEMPERATURE RANGE (°C) : -25 , +70
 STORAGE TEMPERATURE RANGE (°C) : -40 , +85

(* : average power at 25° C per RF path)

4112-9212 This information is given as an indication. In the continual goal to improve our products, we reserve the right to make any modifications judged necessary

DRAWING

General tolerance: ± 0,5 mm

R573 902 680

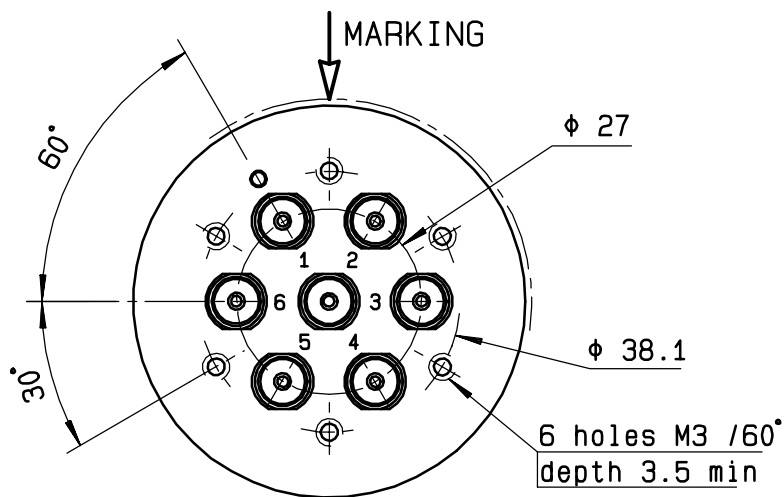

BCD TRUTH TABLE			
E3	E2	E1	RF continuity
0	0	0	LAST SELECTED POS
1	1	1	ALL PORTS OPEN
0	0	1	IN ↔ 1
0	1	0	IN ↔ 2
0	1	1	IN ↔ 3
1	0	0	IN ↔ 4
1	0	1	IN ↔ 5
1	1	0	IN ↔ 6

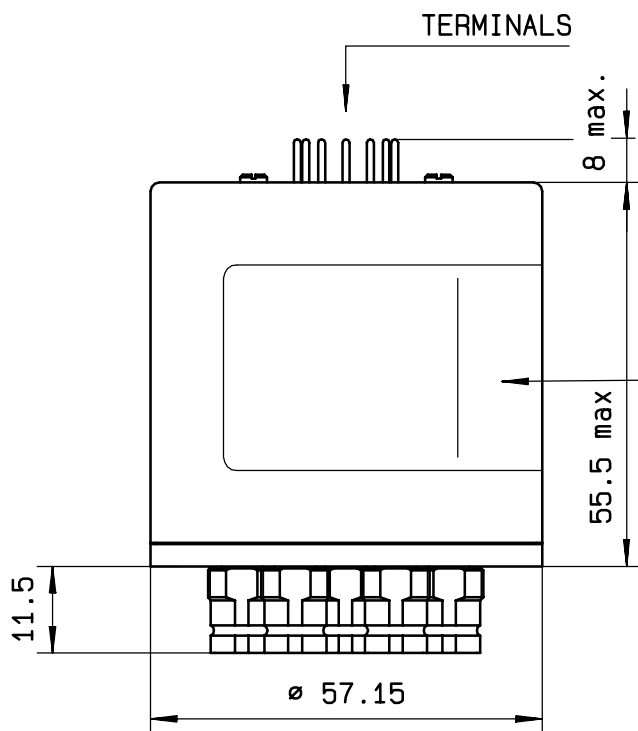

MARKING TOP VIEW (TERMINALS)

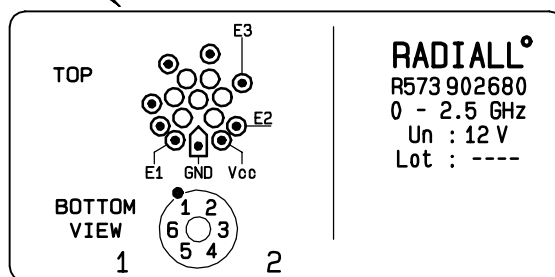

SCHEMATIC DIAGRAM

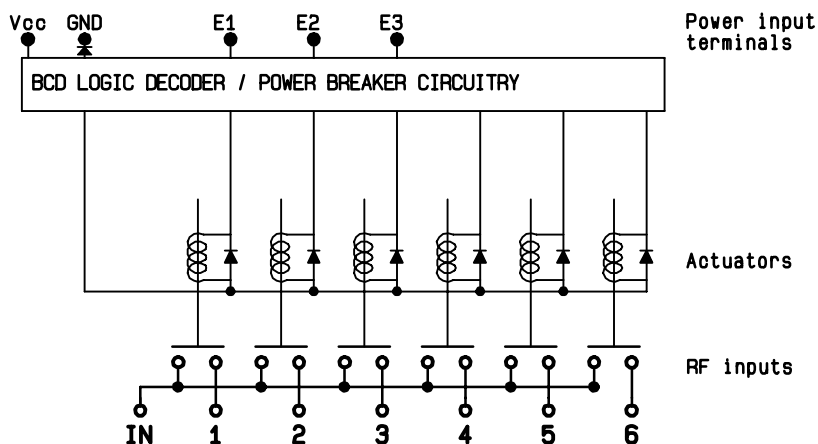

4113-9212 This information is given as an indication. In the continual goal to improve our products, we reserve the right to make any modifications judged necessary