

PART NUMBER	ENGINEERING NO.	LENGTH
1300060529	103002A01F030	3' +1.75 - 0 [0.9M +44.5 - 0]
1300060534	103002A01F060	6' +2.19 - 0 [1.8M +55.6 - 0]
1300060542	103002A01F120	12' +3.50 - 0 [3.7M +88.9 - 0]
1300060549	103002A01F200	20' +6.50 - 0 [6.1M +165.1 - 0]

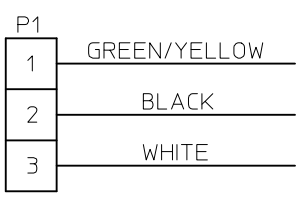

- NOTES:
1. MATERIAL: SEE TABLE
 2. FINISHES: SEE TABLE
 3. CABLE ASSEMBLIES ARE BAGGED SEPERATELY IN POLY BAGS WITH BARCODE LABEL ATTACHED TO OUTSIDE OF BAG
 4. WRAP LABEL IS MARKED WITH P/N, DATE CODE VOLTAGE & AMPERAGE
 5. MATES WITH: MINI CHANGE, A-SIZE 3 POLE RECEPTACLE
 6. ELECTRICAL SPECIFICATIONS:
VOLTAGE RATING: 600V
CURRENT RATING: 13 AMPS
 7. ASSEMBLY IS RoHS COMPLIANT

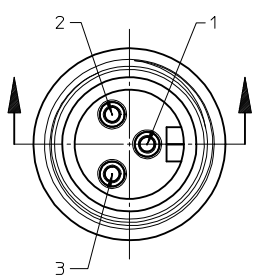
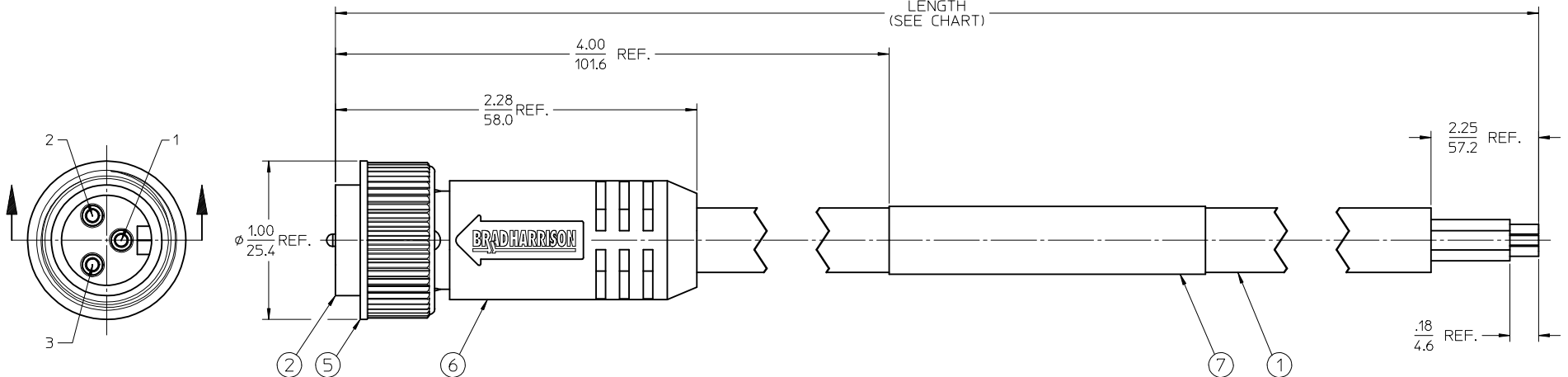
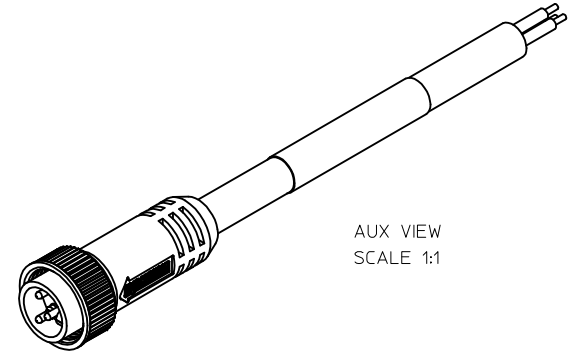
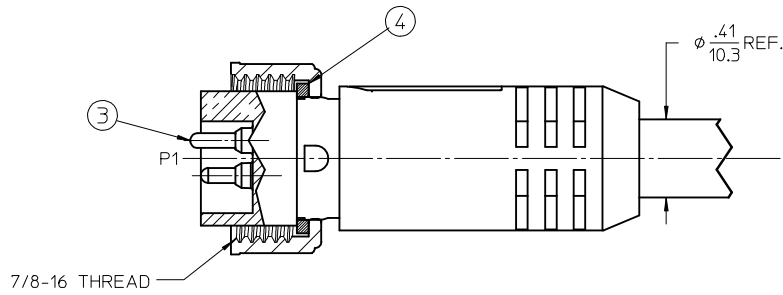
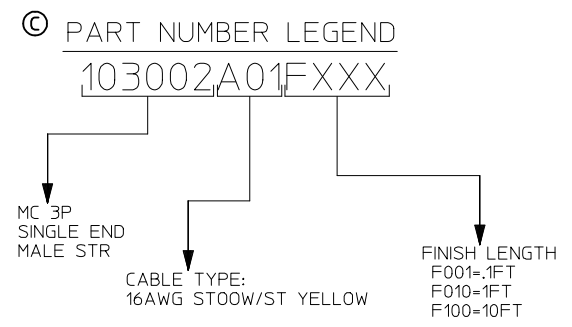

ITEM	QTY.	DESCRIPTION	MATERIAL	FINISH
7	1	LABEL	PLASTIC FILM	BLACK/YELLOW
6	1	OVERMOLD, STRAIGHT	PVC	YELLOW
5	1	COUPLING NUT, FEMALE	ZINC DIE CAST	BLACK
4	1	FRICITION RING	NYLON	WHITE
3	3	CONTACT PIN, 16 AWG	BRASS	GOLD PLATED
2	1	INSERT, MALE, 3 POLE	PVC	YELLOW
1	1	CABLE, STOOV/ST #16/3	PVC JACKET	YELLOW ©

ADDED PART NO. LEGEND
 EC NO: JFG2016-0872
 DRAWINGGUSTAFSON 2015/12/10
 CHKD:HZL/ELIN 2015/12/22
 APPR:BMWOODMAN 2015/12/17

QUALITY SYMBOLS ▽=0 ▽=0	GENERAL TOLERANCES (UNLESS SPECIFIED)	DIMENSION STYLE IN/MM	SCALE 1.5:1	DESIGN UNITS INCH	THIRD ANGLE PROJECTION																												
	<table border="1"> <thead> <tr> <th></th> <th>mm</th> <th>INCH</th> </tr> </thead> <tbody> <tr> <td>4 PLACES ±</td> <td>---</td> <td>±---</td> </tr> <tr> <td>3 PLACES ±</td> <td>---</td> <td>±.005</td> </tr> <tr> <td>2 PLACES ±</td> <td>---</td> <td>±.010</td> </tr> <tr> <td>1 PLACE ±</td> <td>---</td> <td>±.020</td> </tr> </tbody> </table>		mm	INCH	4 PLACES ±	---	±---	3 PLACES ±	---	±.005	2 PLACES ±	---	±.010	1 PLACE ±	---	±.020	<table border="1"> <thead> <tr> <th>DRAWN BY</th> <th>DATE</th> </tr> </thead> <tbody> <tr> <td>LHARTMANN</td> <td>2009/06/05</td> </tr> </tbody> </table>	DRAWN BY	DATE	LHARTMANN	2009/06/05	<table border="1"> <thead> <tr> <th>CHECKED BY</th> <th>DATE</th> </tr> </thead> <tbody> <tr> <td>RSTONE</td> <td>2009/06/08</td> </tr> </tbody> </table>			CHECKED BY	DATE	RSTONE	2009/06/08	<table border="1"> <thead> <tr> <th>APPROVED BY</th> <th>DATE</th> </tr> </thead> <tbody> <tr> <td>JFMURPHY</td> <td>2009/06/08</td> </tr> </tbody> </table>		APPROVED BY	DATE	JFMURPHY
	mm	INCH																															
4 PLACES ±	---	±---																															
3 PLACES ±	---	±.005																															
2 PLACES ±	---	±.010																															
1 PLACE ±	---	±.020																															
DRAWN BY	DATE																																
LHARTMANN	2009/06/05																																
CHECKED BY	DATE																																
RSTONE	2009/06/08																																
APPROVED BY	DATE																																
JFMURPHY	2009/06/08																																
DRAFT WHERE APPLICABLE MUST REMAIN WITHIN DIMENSIONS		SEE CHART		MOLEX INCORPORATED																													
		MATERIAL NO.		DOCUMENT NO.																													
		SIZE		SHEET NO.																													
THIS DRAWING CONTAINS INFORMATION THAT IS PROPRIETARY TO MOLEX INCORPORATED AND SHOULD NOT BE USED WITHOUT WRITTEN PERMISSION																																	